

ANNEXE 1

DEFINITION : ALIGNEMENT

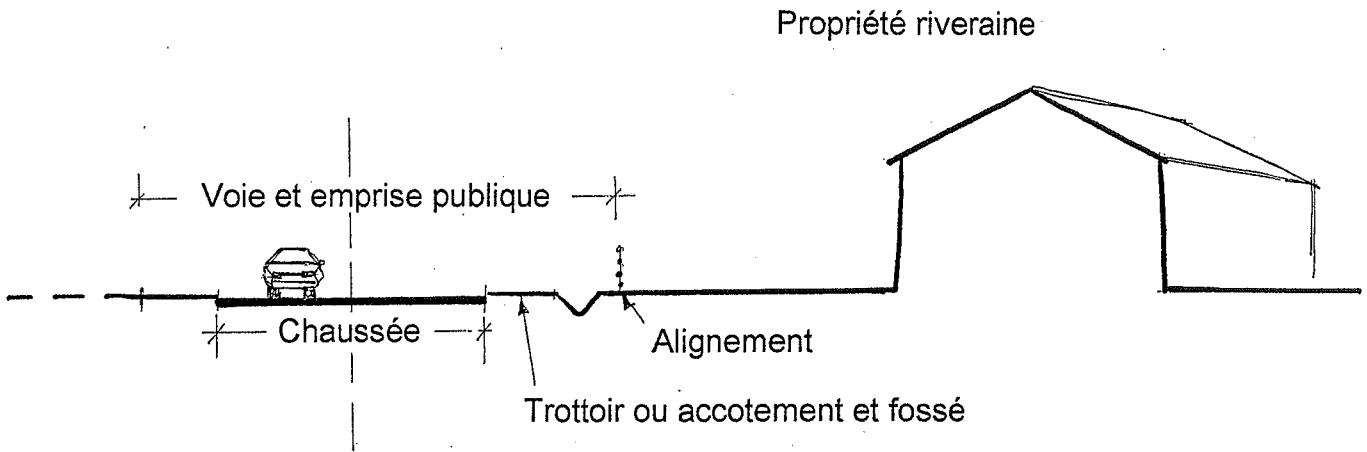

ANNEXE 2

DEFINITION : EMPRISE / TROUEE

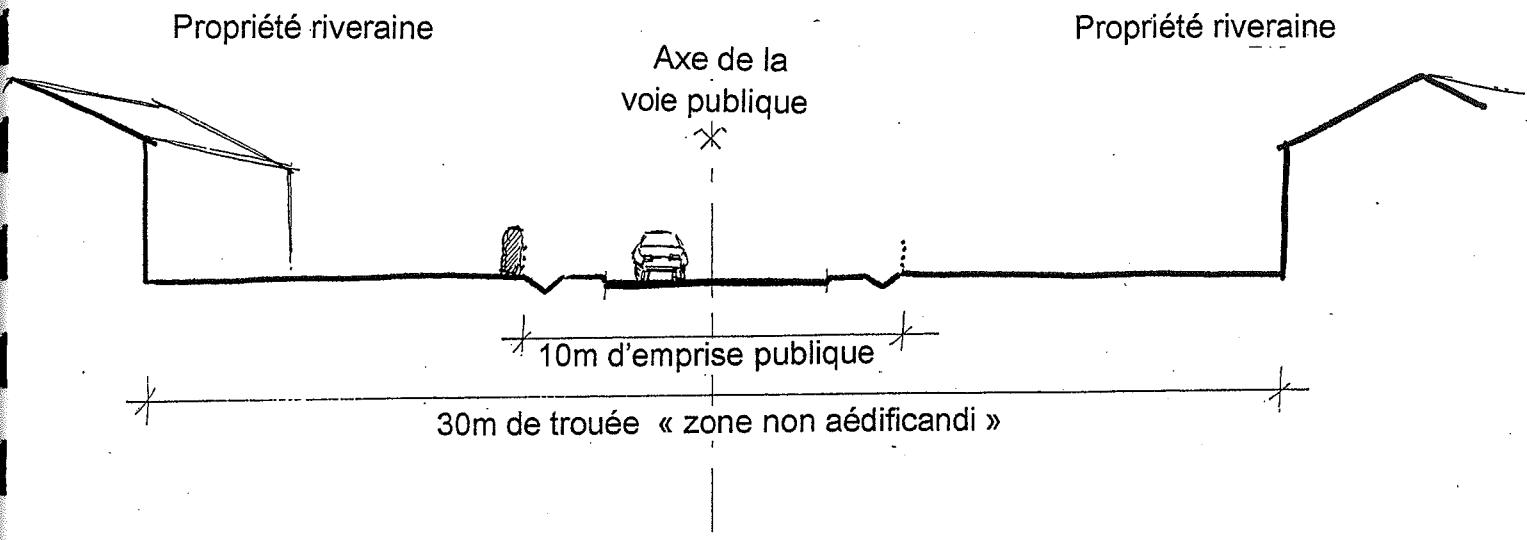

ANNEXE 3

ARTICLE 6 : zone UA

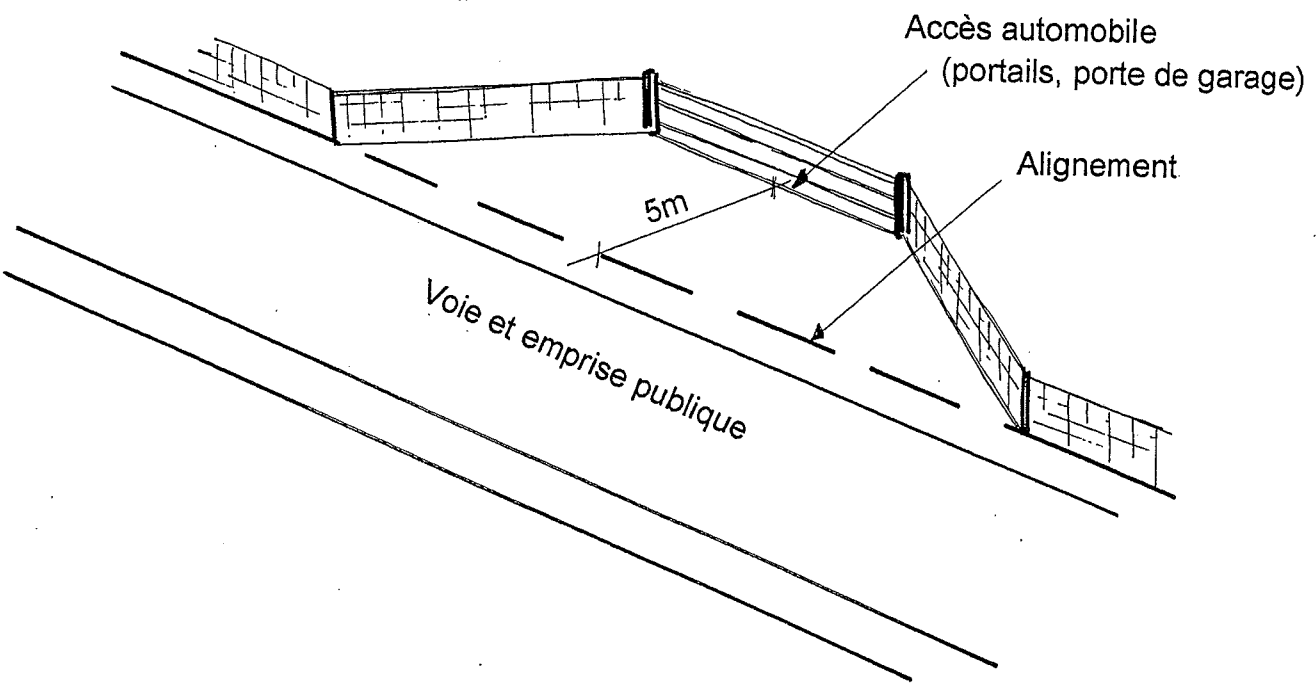
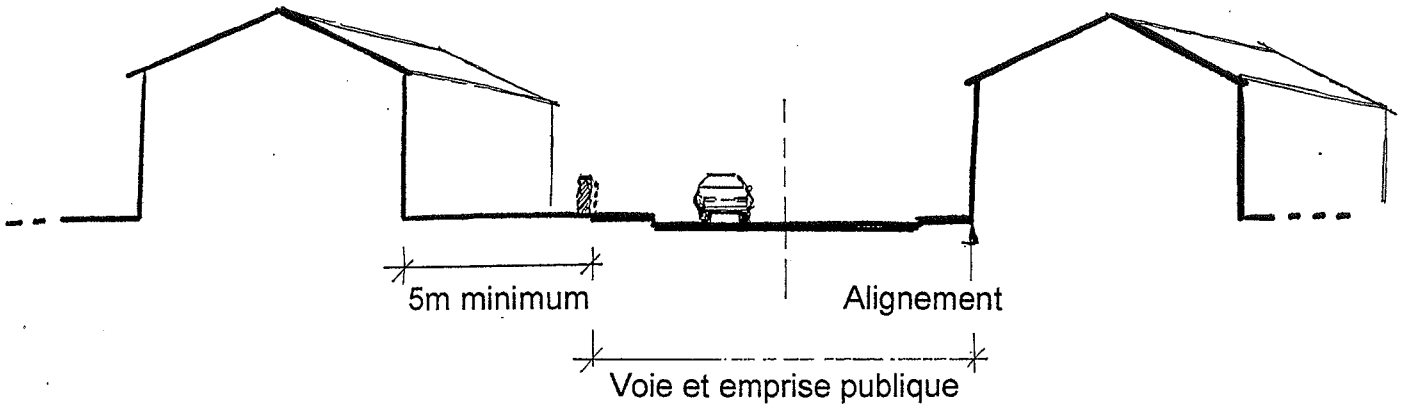

ANNEXE 4

ARTICLE 6 : zone UB

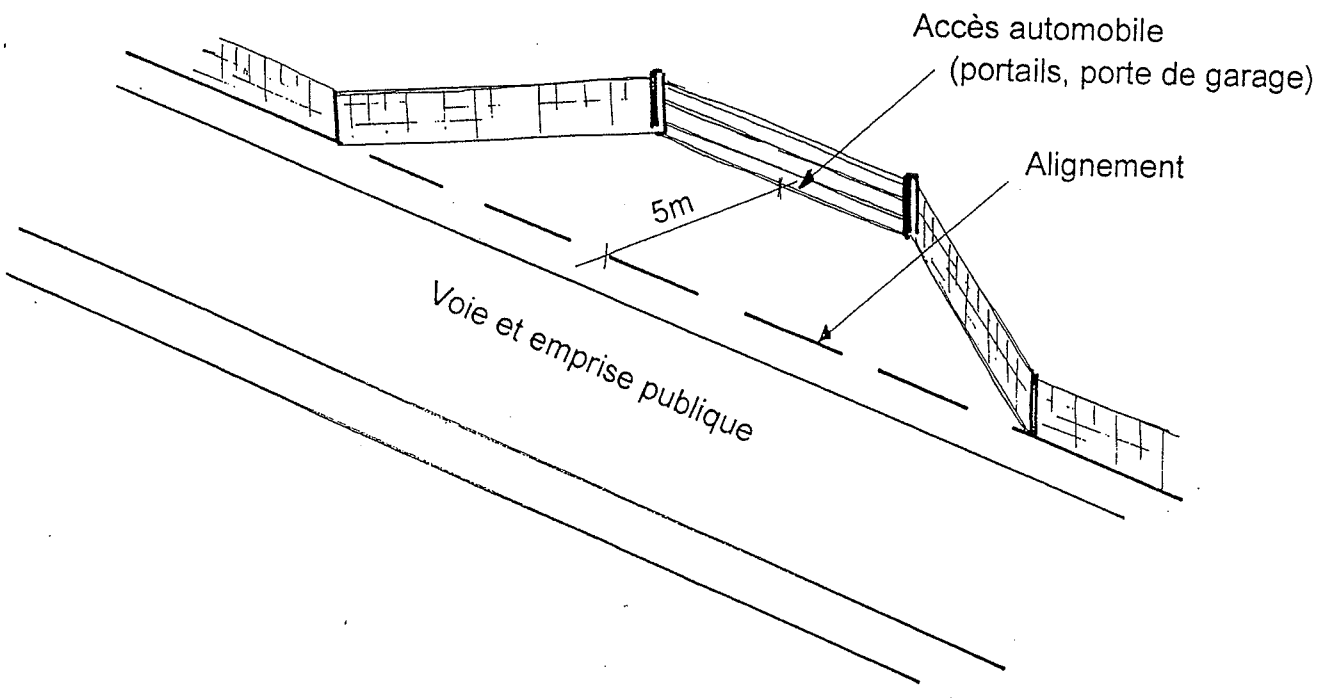
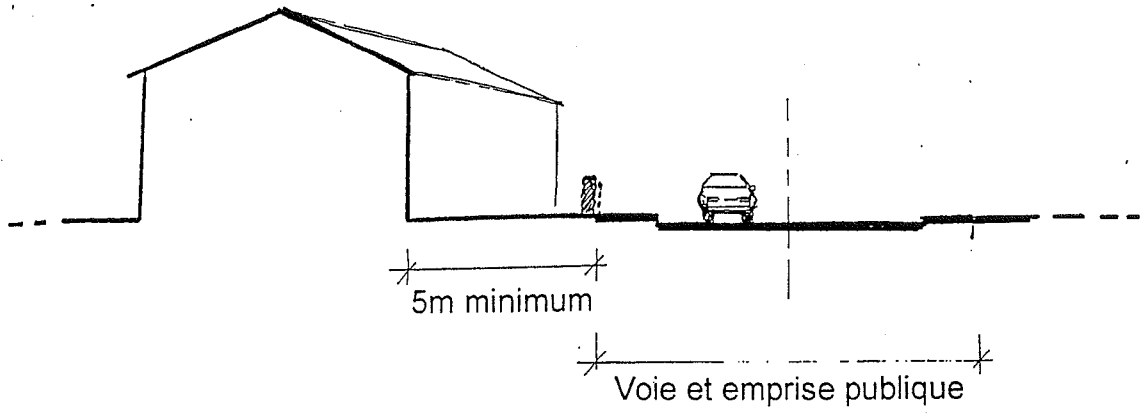

ANNEXE 5

ARTICLE 7 : Zones UA, UB, UC, NAa, NAb, NB

Construction à distance

Limite séparative

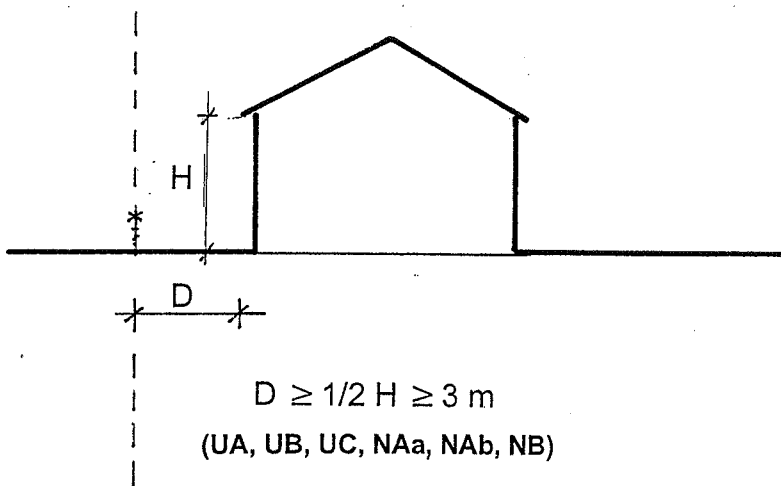

Limite séparative

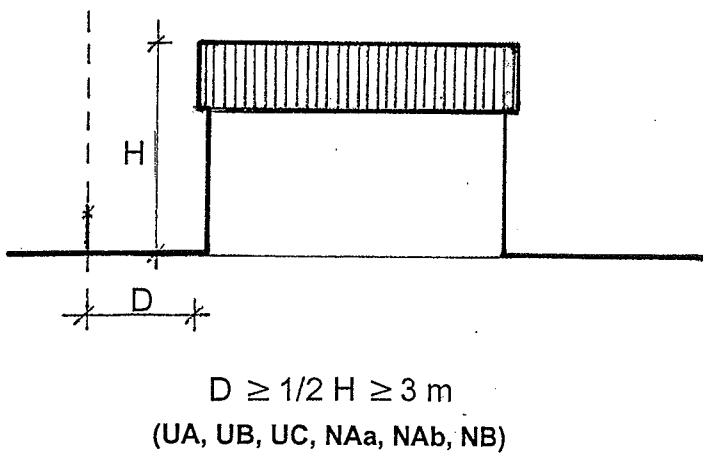

Construction sur limite

Limite séparative

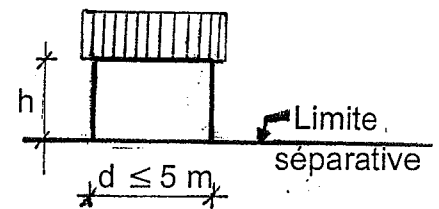
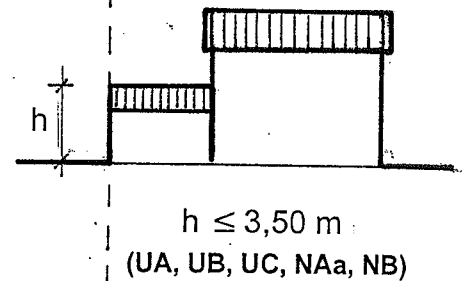
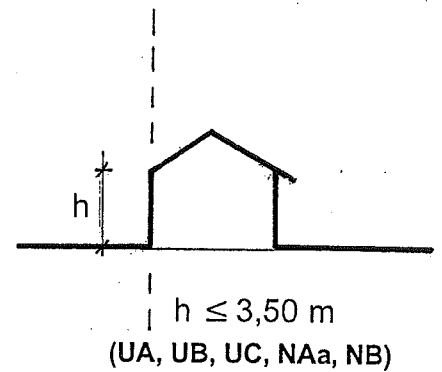

$h \leq 3,50 \text{ m}$
(UB, UC, NAa, NB)

ANNEXE 6

ARTICLE 11 : toutes zones

Clôtures

Système à claire-voie

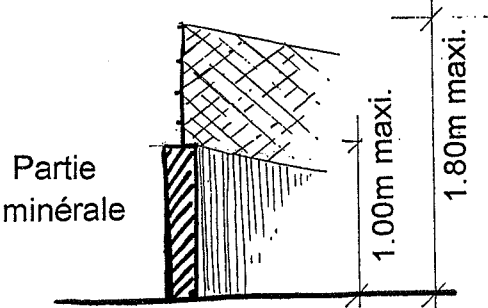

Clôture végétale seule

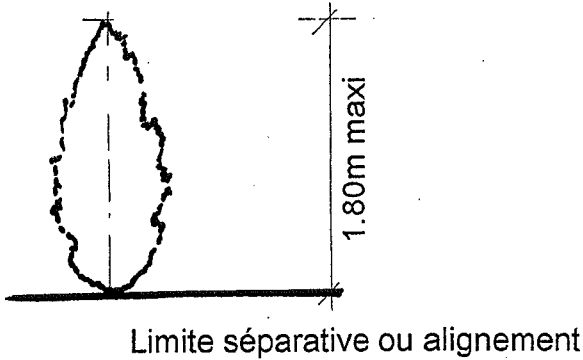

Muret et végétation

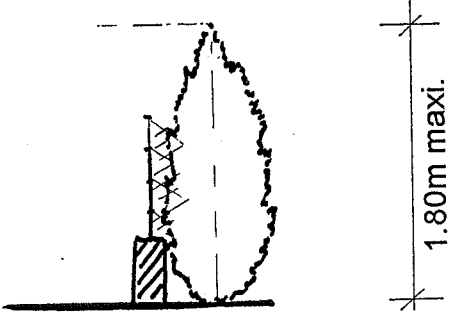

Système à claire-voie seul

